

Raven™
Foldable Base
owners manual

■ K-120 ■ Q/K/CK



Leggett & Platt®
Adjustable Bed Group

CONTENTS

Advisory.....	3
Assembly	5
Remote Control Function.....	10
Remote Control Programming	11
Troubleshooting.....	12
Accessories.....	13
Warranty	14



READ ALL INSTRUCTIONS BEFORE USING

If adjustable base does not operate or if parts are missing, call:
1-800-888-3078

ADVISORY

IMPORTANT INFORMATION

READ THE FOLLOWING INFORMATION CAREFULLY BEFORE USING THIS PRODUCT



WARNING

FOR OPTIMUM ADJUSTABLE BASE OPERATION, USE A GROUNDED, ELECTRICAL SURGE PROTECTION DEVICE (NOT INCLUDED). FAILURE TO USE A SURGE PROTECTION DEVICE COULD COMPROMISE SAFETY OR CAUSE PRODUCT MALFUNCTION.

ELECTRICAL RATING

Input: 100-240VAC, 50/60Hz, 1.6A. Output: 29VDC, 1.8A.

ELECTRICAL GROUNDING

This product is equipped with a polarized or grounded electrical power cord. The power cord will only fit into a grounded, electrical surge protection device (not included) or a grounded electrical outlet.

WARRANTY WARNING

Do not open any control boxes, motors or remote control devices (with the exception of the remote control battery compartment). The product warranty will be void if these components are tampered with. Do not attempt to alter component wiring or adjust or modify the structure of the product in any way or the warranty will be void. Any repair or replacement of base parts must be performed by authorized personnel.

LUBRICATION

This product is designed to be maintenance free. The lift motors are permanently lubricated and sealed—no additional lubrication is required. Do not apply lubricant to lift motor lead screws or any nylon nuts or the base may inadvertently creep downward from the elevated position.

SMALL CHILDREN / PETS WARNING

After the base is unboxed, immediately dispose of packaging material as it can smother small children and pets. To avoid injury, children or pets should not be allowed to play under or on the base. Children should not operate this base without adult supervision.

LOCATION ENVIRONMENT

The level of sound experienced during operation is directly related to the location environment. For example, when a base is located on a hardwood floor with the massage feature in operation, a vibrating tone will be audible.

PRODUCT RATINGS

The base lift motors are *not* designed for continuous use. Reliable operation and full life expectancy will be realized as long as the lift motors do not operate any more than two (2) minutes over a twenty (20) minute period, or approximately 10% duty cycle.

Note: Massage equipped bases are not designed for continuous, extended massage operation. Massage systems are rated for a maximum of 2 hours of use within any 6 hour period. Any attempt to circumvent or exceed product ratings will shorten the life expectancy of the product and may void the warranty.

The recommended weight restrictions for these adjustable bases is 850 lb (385 kg) all sizes. The base will structurally support the recommended weight distributed evenly across the head and foot sections. This product is not designed to support or lift this amount in the head or foot sections alone. **Note: Exceeding the recommended weight restrictions could damage the base and void the warranty.** Depending on the size and/or model of mattress, the available weight capacity may be less.

For best performance, consumers should enter and exit the adjustable base with the base in the flat (horizontal) position. **DO NOT SIT ON THE HEAD OR FOOT SECTIONS WHILE IN THE RAISED POSITION.**

Motors and electronics have been ETL tested to UL (Underwriters Laboratories) standard UL962. CFR 1633 approved for use with most mattresses. Assembled in USA.

ADVISORY

IMPORTANT INFORMATION

READ THE FOLLOWING INFORMATION CAREFULLY BEFORE USING THIS PRODUCT

PACEMAKER WARNING

This product produces a vibrating sensation. It is possible that individuals with heart-assist pacemakers may experience a sensation similar to exercise. Consult physician for complete information.

HOSPITAL USE DISCLAIMER

This base is designed for in-home use only. It is not approved for hospital use and does not comply with hospital standards. Do not use this base with tent type oxygen therapy equipment, or use near explosive gases. Manufacturer makes no representation or warranty that the adjustable base constitutes a medical device or is suitable for medical or therapeutic use.

SERVICE REQUIREMENTS

Service technicians are not responsible for moving furniture, removing headboards and footboards or any items required to perform maintenance on the base. In the event the technician is unable to perform service due to lack of accessibility, the service call will be billed to the purchaser and the service will have to be rescheduled.

LIFTING/LOWERING MECHANISMS

The lift/lower feature will emit a minimal humming sound during operation. This is normal.

During operation, the lift arm wheels make contact with the platform support of the base. This applies slight tension on the moving components and resonance is reduced to a minimum level. If excessive noise or vibration is experienced, reverse the movement action (up or down) of the base with the remote control. This should realign the base's activating mechanisms to the proper operational position.

FCC COMPLIANCE

The equipment has been tested and found to comply with the limits for a Class B digital device, pursuant to Part 15 of the FCC Rules. These limits are designed to provide reasonable protection against harmful interference when the equipment is operated in a residential environment. This equipment generates, uses, and can radiate radio frequency energy and, if not installed and used in accordance with the instruction manual, may cause harmful interference to radio communications. However, there is no guarantee that interference will not occur in a particular installation. If this equipment does cause harmful interference to radio or television reception, which can be determined by turning off the equipment off and on, the user is encouraged to try to correct the interference by one or more of the following measures:

- Reorient or relocate the receiving antenna
- Increase the separation between the equipment and receiver.
- Connect the equipment into an outlet on a circuit different from that to which the receiver is connected.
- Consult the dealer or an experienced radio/TV technician for help.

This device complies with Part 15 of the FCC rules. Operation is subject to the following conditions: (1) This device may not cause harmful interference, and (2) this device must accept any interference received, including interference that may cause undesired operation.

FCC Caution: Any changes or modifications not expressly approved by the party responsible for compliance could void the user's authority to operate this equipment.

Radio Frequency = 2.4 GHz.

ASSEMBLY

STEP 1

Place adjustable base shipping container on solid, level surface. Remove top section of shipping container. Remove packing material. Carefully, lift adjustable base out of bottom section of shipping container and place on clean surface. **Note: Allow for enough space to unfold base in setup area.**

Unfold base until flat.

Remove hardware/leg boxes. Before discarding any packing materials, verify the following items are included:

- (6) Bed legs
- (1) Remote Control
- (2) AAA Batteries
- (1) Power Supply
- (2) Bolts
- (2) Captive Pins
- (1) Mattress Retainer (cut zip-tie to remove)
- (1) Warranty Activation Card
- (1) Owners Manual



6 - LEGS



1 - REMOTE CONTROL



2 - AAA BATTERIES



1 - POWER SUPPLY
(power brick and electrical power cord)



2 - BOLTS & CAPTIVE PINS

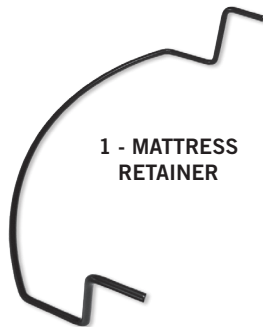

1 - MATTRESS
RETAINER



1 - OWNERS MANUAL



1 - WARRANTY
ACTIVATION CARD

ASSEMBLY

STEP 2

Align lower holes at hinge. On each side of base, insert bolt through hole (in opposite direction of existing bolt) (FIGURE 1).

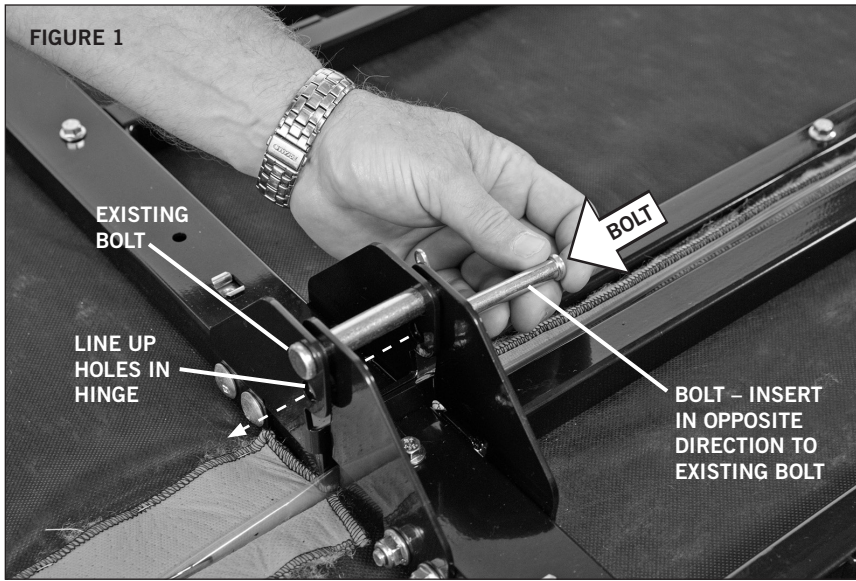

STEP 3

Insert captive pins into bolts to secure bolts (FIGURE 2).



ASSEMBLY

STEP 4

Install (4) legs into the tapped fittings at the four corners of the base frame (FIGURE 3). Install (2) legs at the hinge area (FIGURE 4).

Note: Install the (2) legs at the hinge in diagonal position across the center fold of base (FIGURE 4).

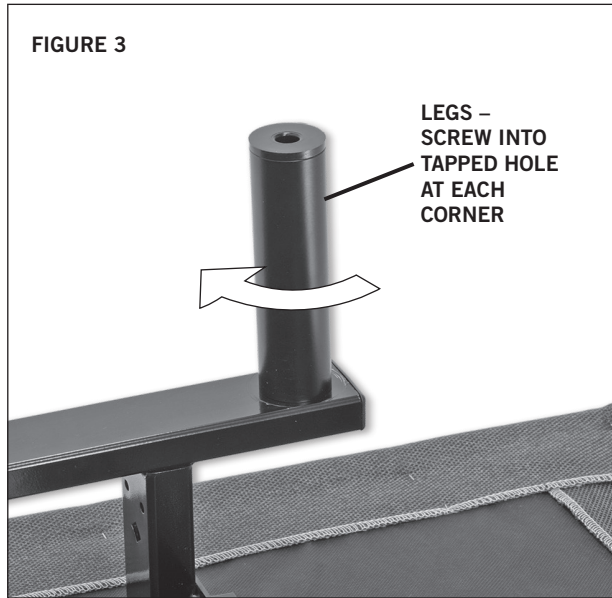

NOTE:
IMAGES SHOWN MAY DIFFER FROM ACTUAL
PRODUCT.

FIGURE 4
INSTALL POINTS
OF CENTER LEGS
(installed diagonally
across center fold)

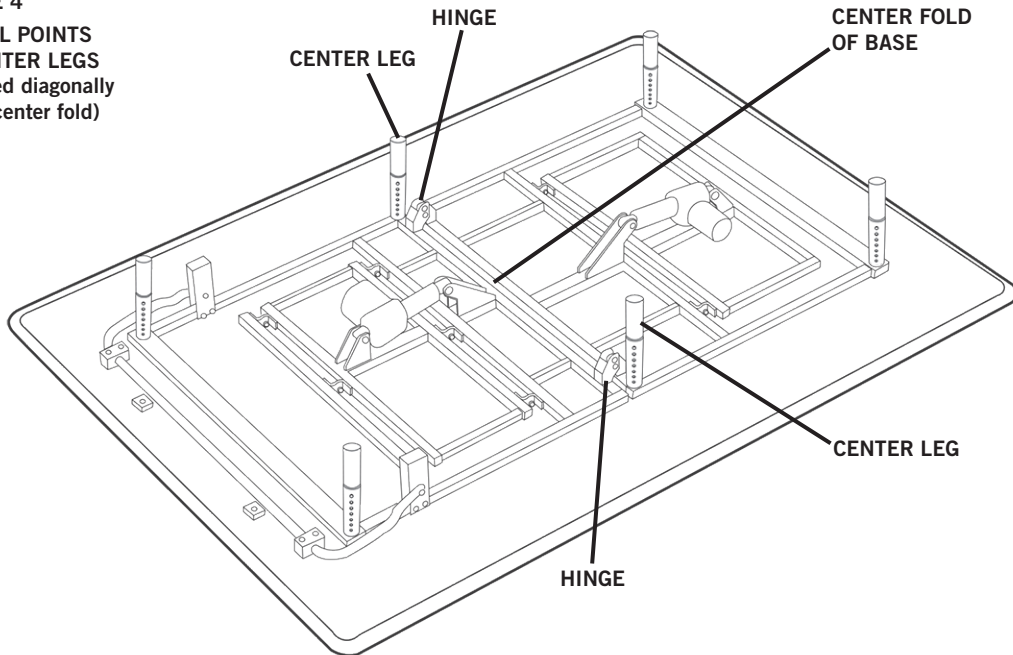

ASSEMBLY

STEP 5

Plug electrical power cord into power brick. Plug brick power cord into base motor cable. Secure connection using cable latch (FIGURE 5). Note: Align pins before inserting plugs.

Plug electrical power cord into power outlet. Note: An electrical surge protection device is recommended (not included).

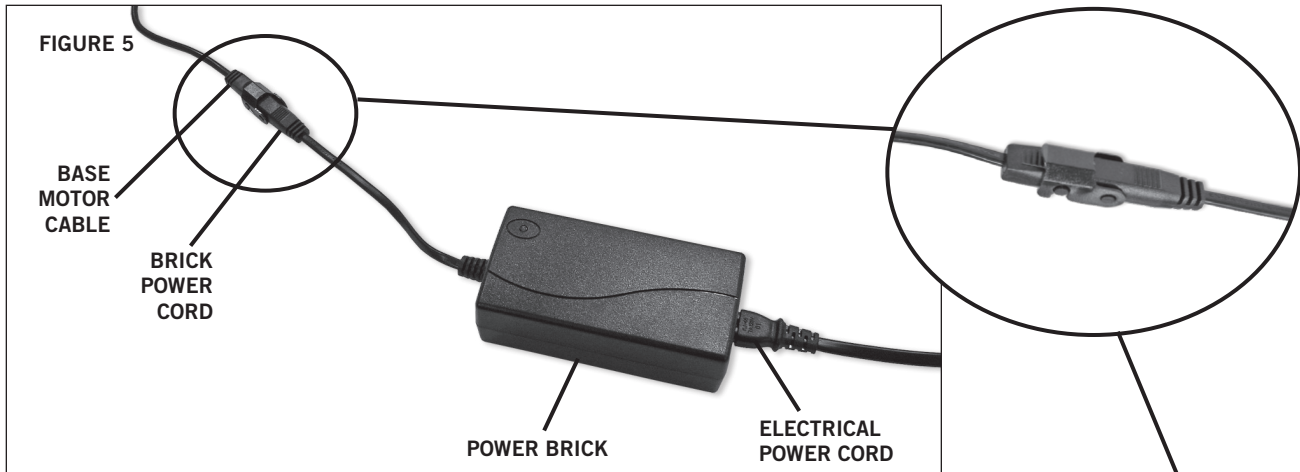
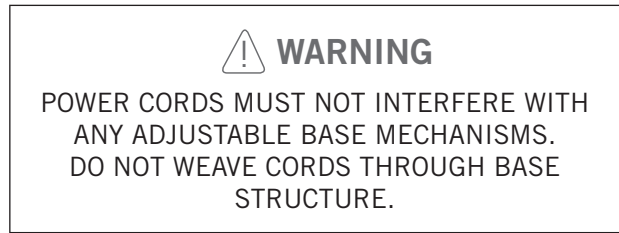

STEP 6

Gently rotate over so base is resting on its legs.

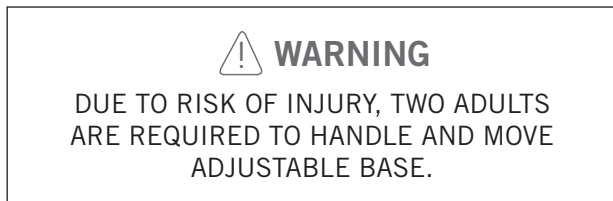

STEP 7

Install 2-AAA batteries in the remote control. Operate remote control to verify base functions properly. If base does not operate, see the Troubleshooting section.

STEP 8

Lower base to flat position.

STEP 9

Remove any protective film from Micro-Hook™ strips.

STEP 10 (OPTIONAL)

Carefully insert base into case good or bed frame, if applicable.

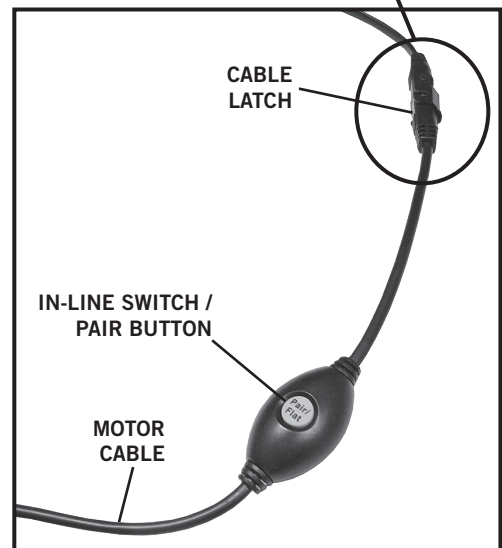

Note: Your base may be equipped with an in-line switch (pair button) as part of the electrical power cord located near the end of the power cord. This can be used in lieu of the learn switch on the control box.

ASSEMBLY

MATTRESS RETAINER INSTALLATION (OPTIONAL)

Base is equipped with a Micro-Hook™ system to captivate the mattress as shown in FIGURE 6, but a mattress retainer can also be used.

Important: If using a dust ruffle or mattress encasement with this product, a mattress retainer must be used.

FIGURE 6

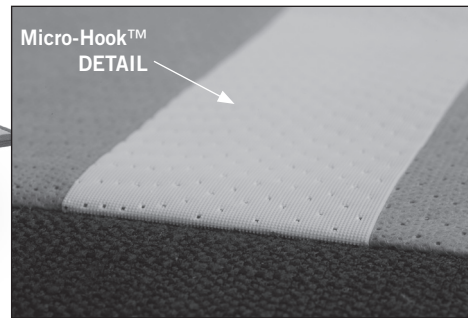
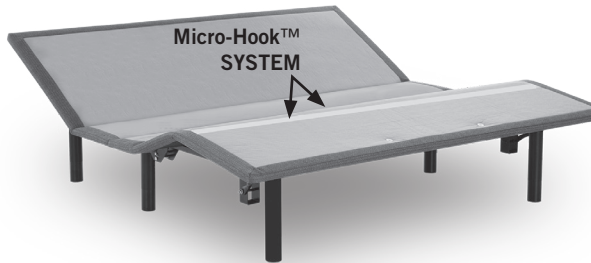

STEP 11

Install the mattress retainer by placing the mattress retainer ends in the holes at the foot end of the base. Make sure horizontal bar section is flush against the base (FIGURE 7).

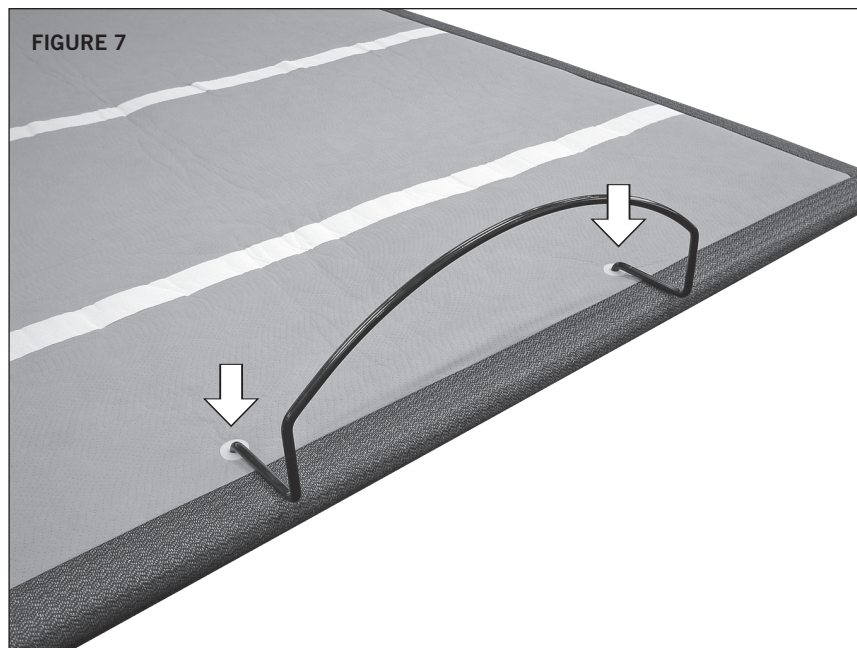

STEP 12

Place mattress on base to complete assembly.

REMOTE CONTROL FUNCTION

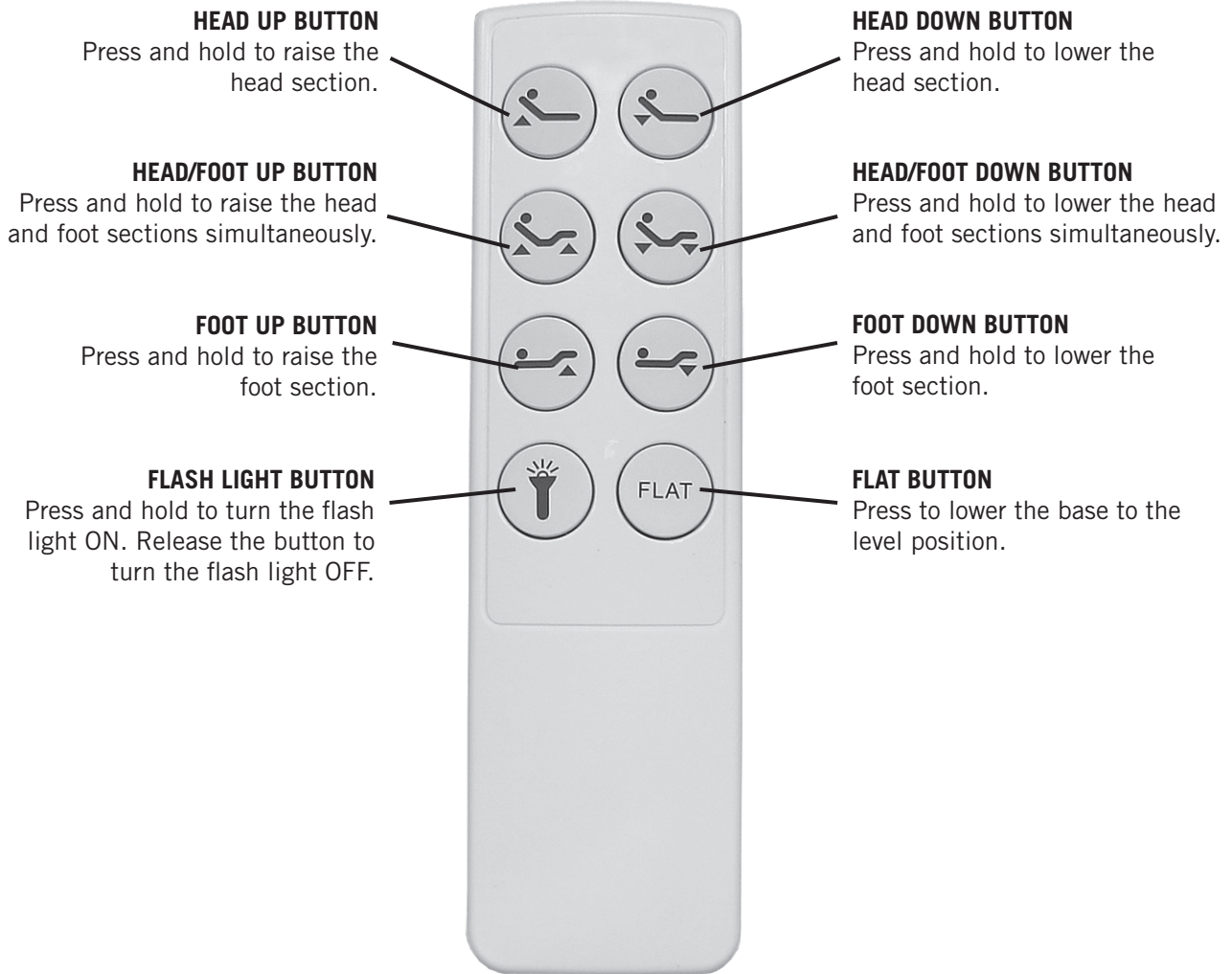

NOTE

REMOTE CONTROL REQUIRES (2) AAA SIZE BATTERIES. TO CONSERVE BATTERY LIFE, THE TRANSMITTER TURNS OFF ALL FUNCTIONS WHEN ANY BUTTON IS PRESSED FOR MORE THAN 50 SECONDS.

REMOTE CONTROL PROGRAMMING - 1 REMOTE TO OPERATE 1 BASE

STEP 1

Plug base into power outlet.

STEP 2

Simultaneously press and hold both the HEAD DOWN and FOOT UP buttons on the remote control (FIGURE 8). While holding these buttons, press and hold the LEARN button on the control box (FIGURE 9) or the PAIR button on the in-line switch (FIGURE 10), as equipped. Hold until you hear an audible sound, then release all buttons.

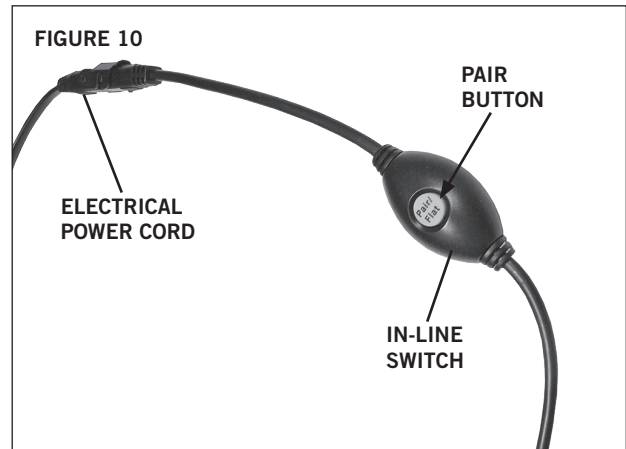
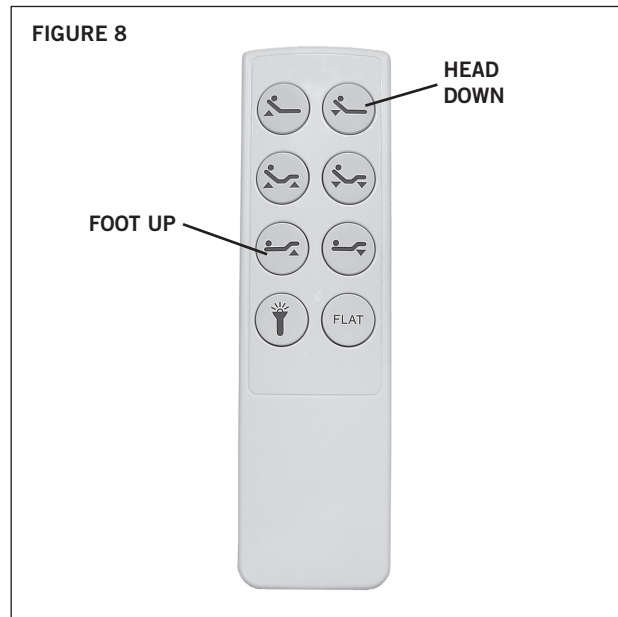
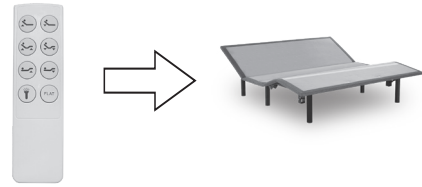

Note: Your base may be equipped with an in-line switch (pair button) as part of the electrical power cord located near the end of the power cord. This can be used in lieu of the learn switch on the control box.

STEP 3

Operate the remote control to verify the base functions correctly.

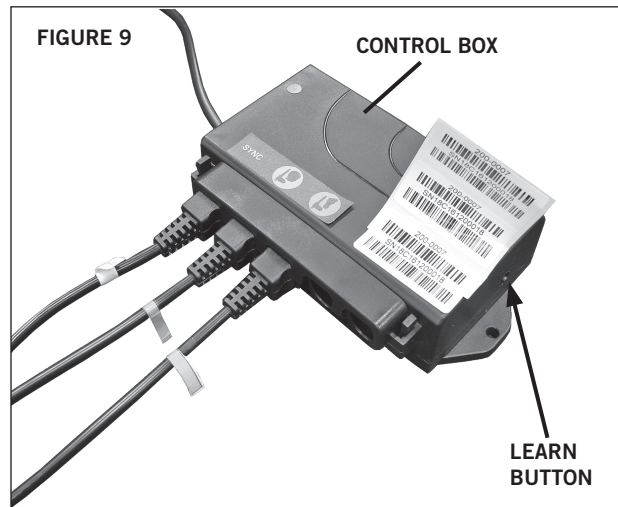

TROUBLESHOOTING

If the adjustable base fails to operate, investigate the symptoms and possible solutions provided in the chart below:

SYMPTOM	SOLUTION
Remote control illuminates and appears to be operable, but will not activate base.	<ul style="list-style-type: none"> • Verify power cord is plugged into a working, grounded electrical outlet. A grounded, electrical surge protection device is recommended. Test outlet by plugging in another working appliance. • If the base was operated over the rated duty cycle, thermal switch opens. Wait 30 minutes before trying to operate the base. Once the base resumes normal operation, do not exceed the duty cycle.
No features of the base will activate.	<ul style="list-style-type: none"> • Program the remote control (see <i>Remote Control Programming</i> section of this manual for programming procedures). • Unplug power cord, wait 30 seconds and plug in to reset electronic components. • Electrical circuit breaker may be tripped. Check electrical service breaker box to verify. • Defective surge protection device or electrical outlet. Test outlet by plugging in another working appliance.
Remote control will not illuminate.	<ul style="list-style-type: none"> • Replace batteries in the remote control.
Head or foot section will elevate, but will not return to the horizontal (flat) position.	<ul style="list-style-type: none"> • Base mechanism may be obstructed. Elevate base and check for obstruction. Remove obstruction. • Head section may be too close to the wall. • Headboard (if used) may be too close the edge of the mattress. Verify a 1.5" (38.1mm) to 2" (50.8mm) distance between headboard brackets and mattress. Adjust if required.

ACCESSORIES

Contact customer service toll free (800-888-3078) to order accessories listed below.

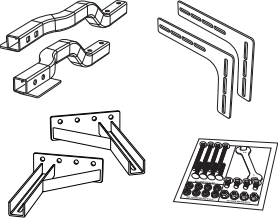
ACCESSORY DESCRIPTION	CODE	IMAGE
Headboard Brackets	4B9245	 The image shows several line drawings of metal brackets and hardware. On the left, there are two L-shaped brackets with slots. In the center, there are two longer brackets with slots and mounting holes. On the right, there is a single L-shaped bracket with a slot and a mounting hole. At the bottom right, there is a small rectangular tray containing several screws and bolts.

1 YEAR, 3 YEAR AND 25 YEAR LIMITED WARRANTY

In this warranty: “**Adjustable base**” means the adjustable bed foundation sold by L&P to the dealer. The “adjustable base” does not include the mattress. “**L&P**” means Leggett & Platt, Incorporated. “**Purchaser**” and “**You**” both mean the consumer who is the original purchaser of this adjustable base made by L&P. This warranty is not transferrable. “**Warranty Commencement Date**” means either (i) the date You purchased a new and unused L&P adjustable base or (ii) the date of manufacture of this adjustable base if You purchased an L&P adjustable base that has been used as floor or display model. A “replacement part” is a new or used part selected at the sole discretion of the manufacturer, including a refurbished or reinspected part, provided in replacement of a part previously incorporated in the adjustable base. L&P warrants this adjustable base to You on the terms and over the reducing periods of time set out below. All warranty claims require notice from You to be given to L&P in the manner set out below, and to be received by L&P inside the applicable warranty time period.

1ST YEAR FULL WARRANTY

For the first year from the Warranty Commencement Date, your adjustable base is warranted against non-excluded defects in L&P’s workmanship or materials. During the first year from the Warranty Commencement Date, L&P will repair or replace (at no cost to You) any defective adjustable base part, and L&P will pay all authorized labor and transportation costs associated with the repair or replacement of any parts found to be defective.

2ND & 3RD YEAR LIMITED WARRANTY

During the second and third year from the Warranty Commencement Date, L&P will replace any adjustable base part found to be defective and not excluded by this warranty. You are responsible to pay all service and transportation costs related to the costs of receiving and installation of the replacement part.

4TH YEAR TO END OF 25TH YEAR LIMITED WARRANTY

Starting in the fourth year from the Warranty Commencement Date and through to the end of the 25th year from the Warranty Commencement Date, L&P will replace steel and mechanical base parts found to be defective and not excluded by this warranty. **This warranty does not cover any electronics, electrical components, drive motors or massage motors.** You are responsible to pay all service and transportation costs related to receiving and installation of the replacement part and a portion of the cost of the replacement steel and mechanical part, based on the number of months that the base has been owned by you since the fourth anniversary of the Warranty Commencement Date. By the end of the 25th year, no portion of the replacement cost is covered by L&P. You will be required to pay 1/22nd of the then current replacement cost of the part multiplied by the number of years past the third year from the Warranty Commencement Date. This portion is calculated using the following formula: Cost of the replacement part divided by 22 [being the number of years in years 4 to 25 inclusive], multiplied by the number of years you have owned the base since the end of the first 3 years. For example, if you make a claim for a replacement part eligible for this warranty in the 5th year since the Warranty Commencement Date, you would be responsible for paying: \$100 part cost divided by 22, multiplied by 2 = \$9.09.

ADDITIONAL TERMS AND CONDITIONS

This warranty requires notice to be given to L&P of any claim for repairs or replacement parts.

EXCLUSIONS:

This warranty does not apply; (a) to any damage caused by You; (b) if there has been any repair or replacement of adjustable base parts by an unauthorized person; (c) if the adjustable base has been mishandled (whether in transit or by other means), subjected to physical or electrical abuse or misuse, or otherwise operated in any manner inconsistent with the operation and maintenance procedures outlined in the Owner’s Manual and this warranty; (d) to damage to mattresses, fabric, cables, electrical cords or items supplied by dealers (contact the dealer for warranty information on these items); (e) if there has been any modification of the adjustable base **without prior written consent by L&P**; or (f) to costs for unnecessary service calls, including costs for in-home service calls solely for the purpose of educating You about the adjustable base or finding a satisfactory power connection.

This warranty will be void if either the recommended weight restriction is not followed (refer to the advisory section of the Owner’s Manual) or if You sell or give or transfer the base to another person.

Any repairs to or replacement to Your adjustable base or its components under the terms of this limited warranty does not extend the applicable warranty from the Warranty Commencement Date. This time limitation may not apply in some jurisdictions, including the Province of Quebec.

The decision to repair or to replace defective parts under this warranty shall be made, or cause to be made, by L&P at its option and in its sole discretion.

Continued on next page...

1 YEAR, 3 YEAR AND 25 YEAR LIMITED WARRANTY

Repair or replacement shall be the sole remedy of the Purchaser. There shall be no liability on the part of L&P for any special, indirect, incidental, or consequential damages or for any other damage, claim, or loss not expressly covered by the terms of this warranty.

This limited warranty does not include reimbursement for inconvenience, removal, installation, setup time, loss of use, shipping, or any other costs or expenses. L&P and its service technicians will not be responsible for moving furniture or any other items not attached to the adjustable base in order to perform service on the adjustable base.

It is the sole responsibility of You to provide adequate space and accessibility to the adjustable base. In the event that the technician is unable to perform service due to lack of accessibility, the service call will be billed to You and the service will have to be rescheduled.

L&P makes no other warranty whatever, express or implied, and all implied warranties of merchantability and fitness for a particular purpose are disclaimed by L&P and excluded from this agreement.

Some American States do not allow the exclusion or limitation of incidental or consequential damages, so the above limitation or exclusion may not apply to You.

This warranty gives You specific legal rights, and You may also have other rights, which may vary from jurisdiction to jurisdiction. This warranty is valid in all 50 American States, the District of Columbia, Puerto Rico, and all 10 Provinces and 3 Territories of Canada.

For customer service under this limited warranty, give notice to L&P by mail, phone, email or online to the addresses set out below:

Leggett & Platt, Incorporated
PO Box 668
Lexington, North Carolina 27293

toll free phone: 1.800.888.3078

online: lpadjustablebases.com

**PLEASE DO NOT CONTACT YOUR RETAIL DEALER
OR ANY OTHER SERVICE PERSONNEL**

NATIONWIDE CUSTOMER SERVICE toll free: (800) 888-3078

© 2018 Leggett & Platt Adjustable Bed Group, a division of Leggett & Platt Incorporated

